

Light oil - kerosene burners

One stage operation

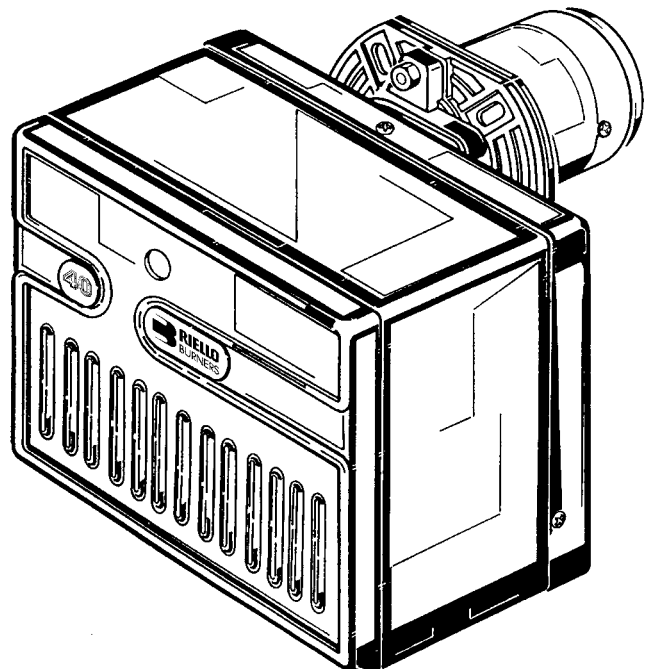

RIELLO 40

CODE	MODEL	TYPE
3744451	G5	444 T50
3744452	G5	444 T50

TECHNICAL DATA

Thermal power – output	28 – 60 kW – 2.3 – 5 kg/h
Fuel	Light oil 35s, max. viscosity at 20 °C: 6 mm ² /s Kerosene 28s
Electrical supply	Single phase, 230V ± 10% ~ 50Hz
Motor	Run current 0.85A – 2850 rpm – 298 rad/s
Capacitor	4 µF
Ignition transformer	Secondary 8 kV – 16 mA
Pump	Maximum pressure 14 bar (203 psi)
Absorbed electrical power	0.16 kW

- Burner with CE marking in conformity with EEC directives: EMC89/336/EEC, Low Voltage 73/23/EEC, Machines 89/392/EEC and Efficiency 92/42/EEC
- The burner meets protection level of IP 40, EN 60529.

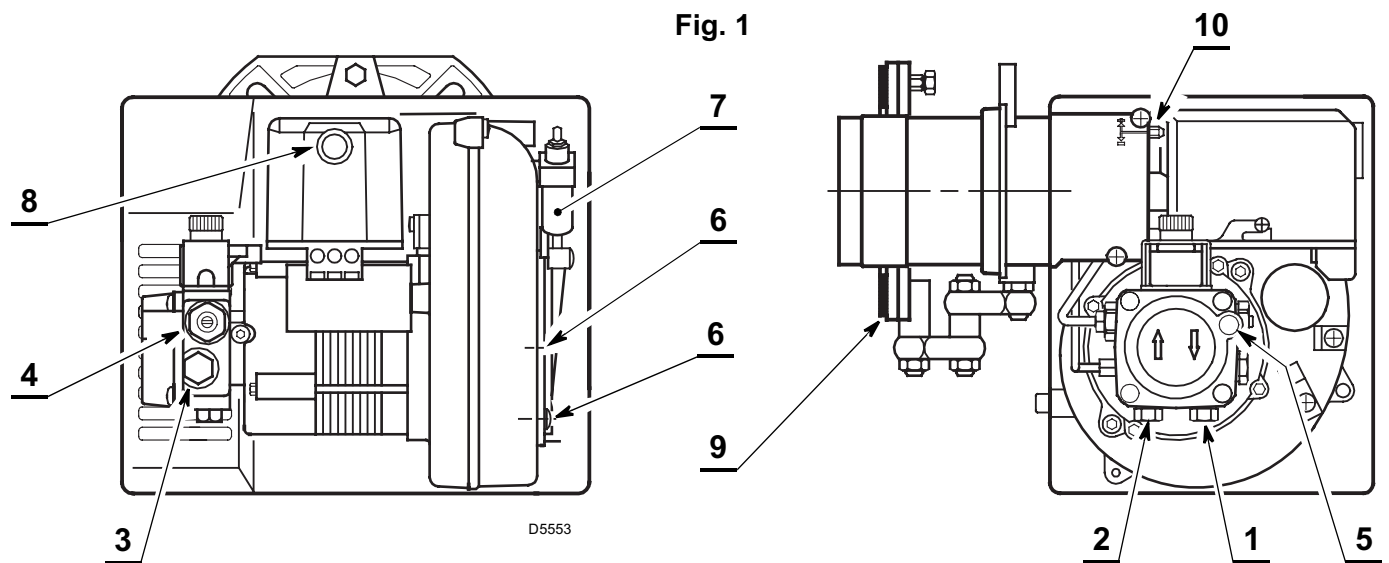

- 1 – Return line
- 2 – Suction line
- 3 – Gauge connection
- 4 – Pump pressure regulator
- 5 – Vacuum gauge connection
- 6 – Screws fixing air-damper
- 7 – Hydraulic jack with air-damper
- 8 – Lock-out lamp and reset button
- 9 – Flange with insulating gasket
- 10 – Combustion head adjustment screw

BURNER EQUIPMENT

Quantity	Description
1	Flexible pipe with nipple
1	Flange with insulating gasket
2	Screws and nuts for flange
1	Hinge
1	Screw of pump by-pass
1	Grommet
1	Screw with two nuts for flange

FIRING RATE, (as EN 267)

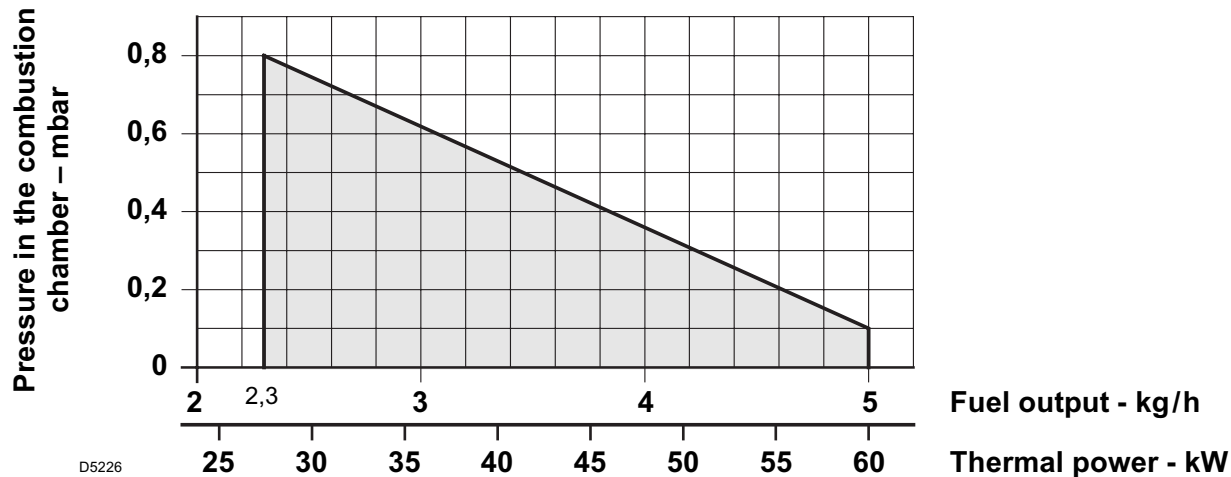

OVERALL DIMENSIONS

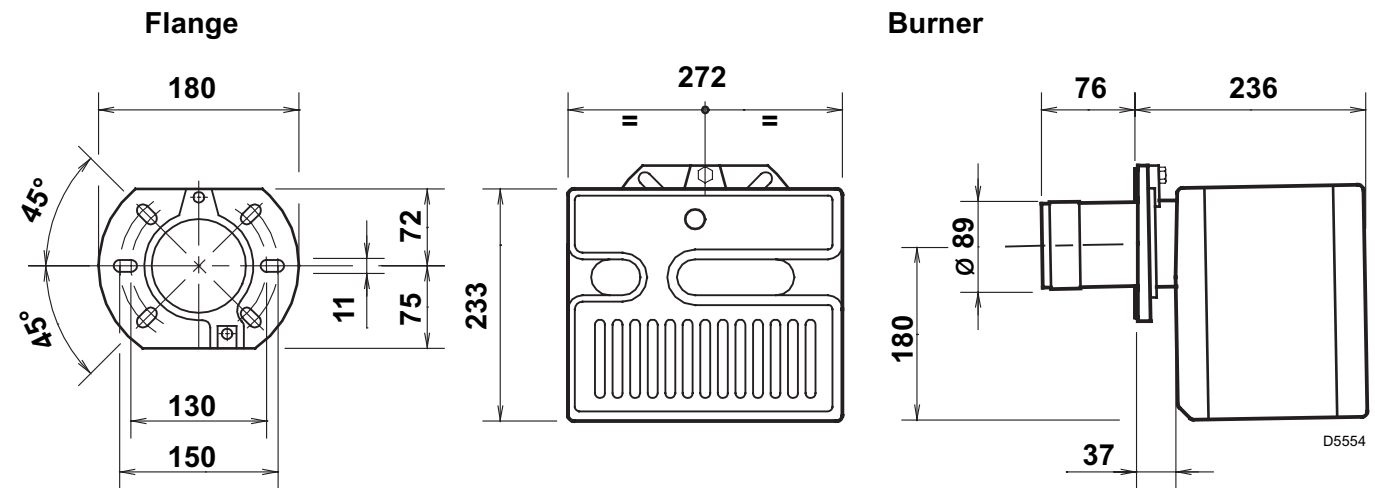

MOUNTING THE BURNER

It is necessary that the insulating gasket (9, fig. 1) is placed between the boiler door and the burner flange.

This insulating gasket has **six holes**, which, if necessary, can be modified as shown on the drawing on the right.

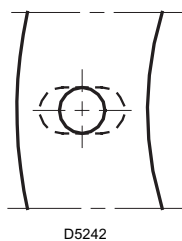

Verify that the installed burner is lightly leaned towards the button.
(See figure 2).

The burner is designed to allow entry of the flexible oil-lines on either side of the burner.

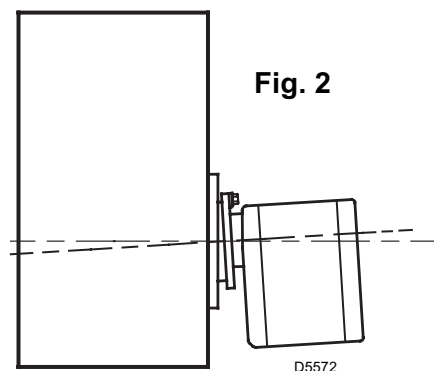

BURNER FIXING AND HINGE ASSEMBLY

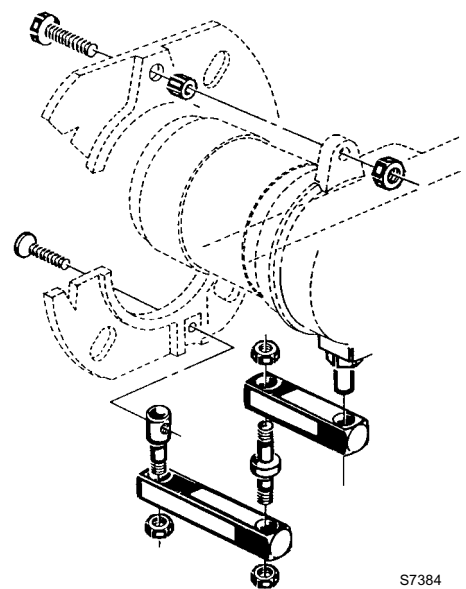

OIL LINES

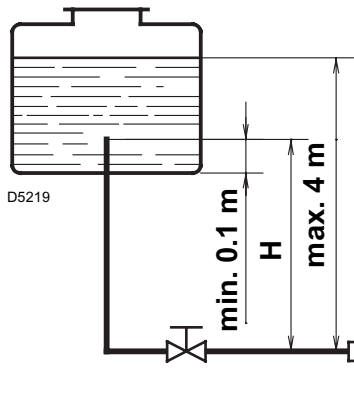

PRIMING THE PUMP

Loosen the plug of the vacuum gauge (5, fig. 1) and wait until the fuel flows out.

H meters	L meters	
	I. D. 8 mm	I. D. 10 mm
0.5	10	20
1	20	40
1.5	40	80
2	60	100

H = Difference of level.

L = Max. length of the suction line.

I.D. = Internal diameter of the oil pipes

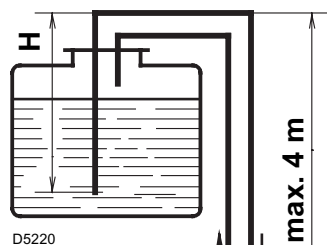

H meters	L meters	
	I. D. 8 mm	I. D. 10 mm
0	35	100
0.5	30	100
1	25	100
1.5	20	90
2	15	70
3	8	30
3.5	6	20

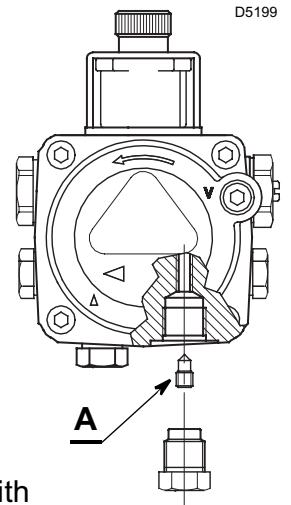

WARNING

The pump is supplied for use with a one pipe system. For use on a two pipe system, it is necessary to screw the **by-pass screw (A)** supplied as burner's accessory. (See figure).

The pump vacuum should not exceed a maximum of 0.4 bar (30 cm Hg). Beyond this limit gas is released from the oil.

Oil lines must be completely airtight.

The return line should terminate in the oil tank at the same level as the suction line; in this case a non-return valve is not required.

Should however the return line arrives over the fuel level, the non-return valve is indispensable.

This solution however is less safe than previous one, due to the possibility of leakage of the valve.

PRIMING THE PUMP:

Start the burner and wait for the priming. Should lock-out occur prior to the arrival of the fuel, await at least 20 seconds before repeating the operation.

Warning: before starting the burner make sure that the return pipe-line is not clogged: any obstruction would cause the pump seals to break.

WARNING:

- ◆ Check periodically the flexible pipes conditions. Using kerosene, they have to be replaced at least **every 2 years**.
- ◆ A metal bowl filter with replaceable micronic filter must be fitted in the oil supply pipe.

ELECTRICAL WIRING

230V ~ 50Hz

WARNING

Do not exchange the neutral with the phase.

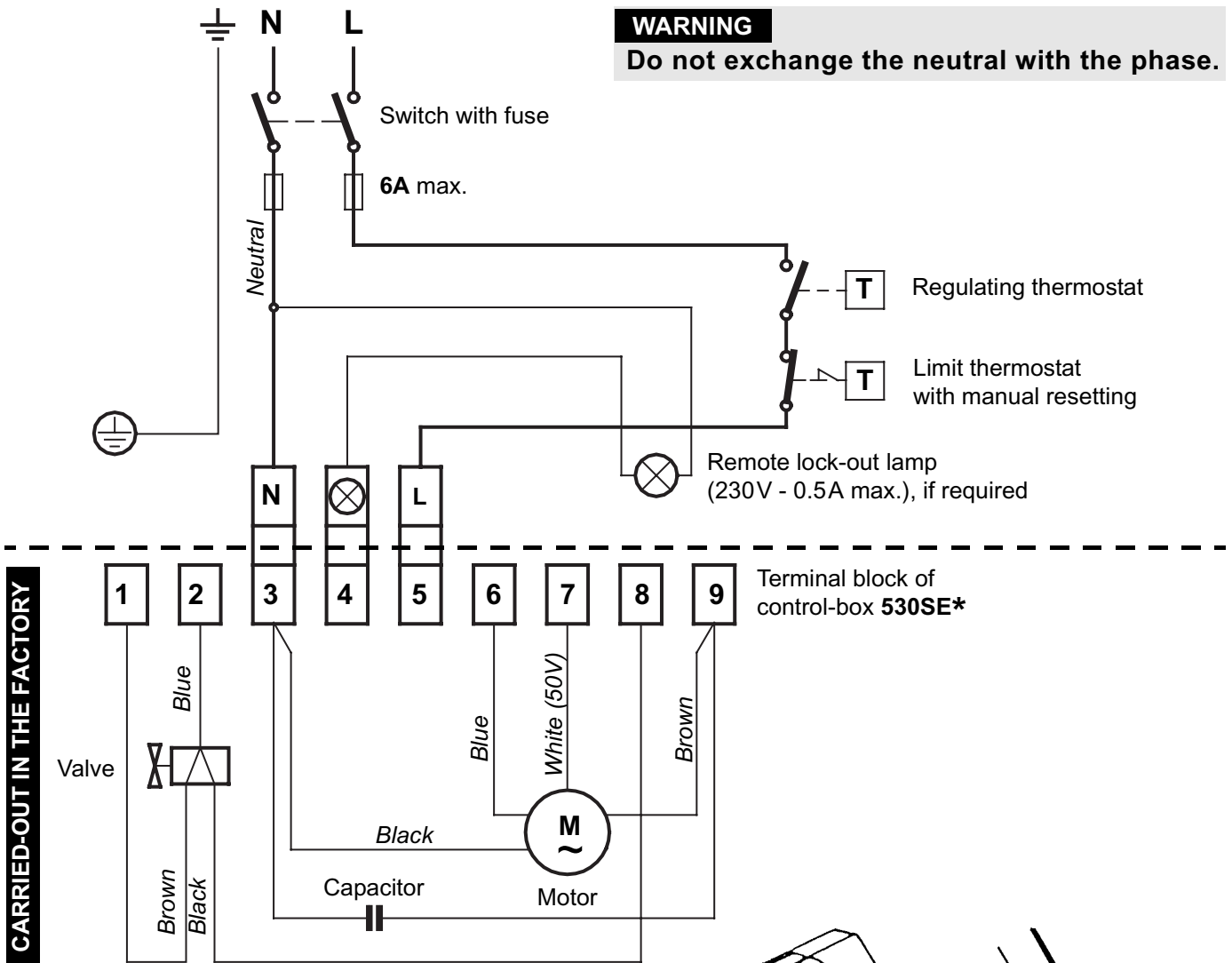

CARRIED-OUT IN THE FACTORY

D5228

NOTES

- Wires of 1 mm² section.
- The electrical wiring carried out by the installer must be in compliance with the rules in force in the Country.
- **To remove the control-box from the burner, loosen screw (A) (see figure) and pull towards the arrow.**
- The photoresistance is fitted directly into the control-box (underneath the ignition-transformer) on a plug-in support.

TESTING

Check the shut-down of the burner by opening the thermostats.

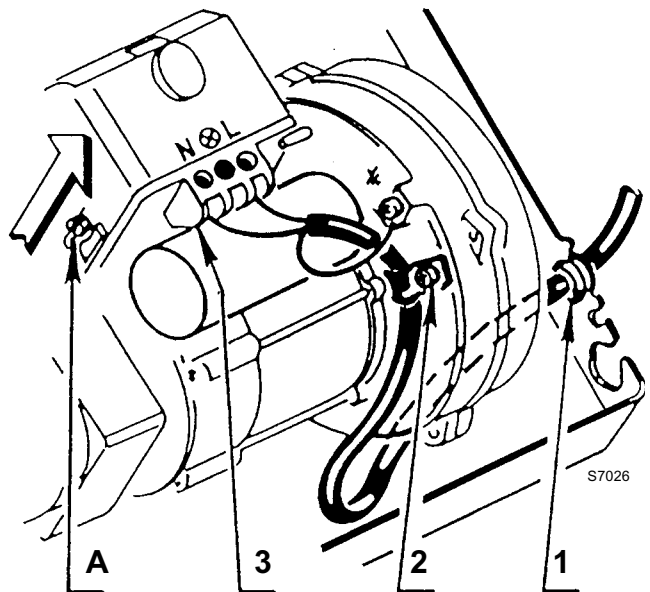

RUN OF THE ELECTRICAL CABLE

- | | |
|--------------------|------------------|
| 1 - Cable gland | N - Neutral |
| 2 - Cable-clamp | L - Phase |
| 3 - Terminal block | ⏏ - Burner-earth |

COMBUSTION ADJUSTMENT

In conformity with Efficiency Directive 92/42/EEC the application of the burner on the boiler, adjustment and testing must be carried out observing the instruction manual of the boiler, including verification of the CO and CO₂ concentration in the flue gases, their temperatures and the average temperature of the water in the boiler.

To suit the required appliance output, fit the nozzle then adjust the pump pressure, the setting of the combustion head and the air damper opening in accordance with the following schedule.

LIGHT OIL FUEL

1		2		3	4
Nozzle		Pump pressure	Burner output	Comb. head adjustment	Air damper adjustment
GPH	Angle	bar	kg/h ± 4%	Set-point	Set-point
0.60	60°/80°	12	2.6	1.5	2
0.65	60°/80°	12	2.8	2	2.2
0.75	60°	12	3.2	2.5	2.5
0.85	60°	12	3.7	3	3
1.00	60°	12	4.3	4	4.5
1.10	60°	12	4.8	5	6
1.10	60°	13	5.0	6	7

KEROSENE FUEL

1		2		3	4
Nozzle		Pump pressure	Burner output	Comb. head adjustment	Air damper adjustment
GPH	Angle	bar	kg/h ± 4%	Set-point	Set-point
0.75	60°	8	2.2	1	2
0.85	60°	8	2.5	1.5	2
1.00	60°	8	2.9	2	2.3
1.10	60°	8	3.2	2.5	2.5
1.25	60°	8	3.7	3	3
1.35	60°	8	4.0	4	4
1.50	60°	8	4.4	5	5
1.50	60°	10	5.0	6	7

1 NOZZLES RECOMMENDED: Monarch type R - NS ; Delavan type W -A - E
Steinen type Q - H ; Danfoss type B - H

Angle: 60° - in most cases.

80° - in case of flame detachment, during ignitions at low temperatures.

2 PRESSURE:

8 bar: the pump leaves the factory set at this value, **which is suitable only for kerosene.**

10 bar: maximum pressure for kerosene.

FOR LIGHT OIL INCREASE PRESSURE

12 bar: in most cases.

14 bar: improves flame retention; it is therefore suitable for ignitions at low temperatures.

3 COMBUSTION HEAD SETTING

This is done when fitting the nozzle, with the blast tube removed. It depends on the output of the burner and is carried out by rotating the regulating rod, till the terminal plane of the blast tube is level with the set-point, as indicated in the schedule.

In the sketch below, the combustion head is set for an output of 0.85 GPH at 12 bar (*for light oil*) or 1.25 GPH at 8 bar (*for kerosene*).

The shutter is level with set-point 3, as required by the schedule at page 5.

Terminal plane of the blast tube

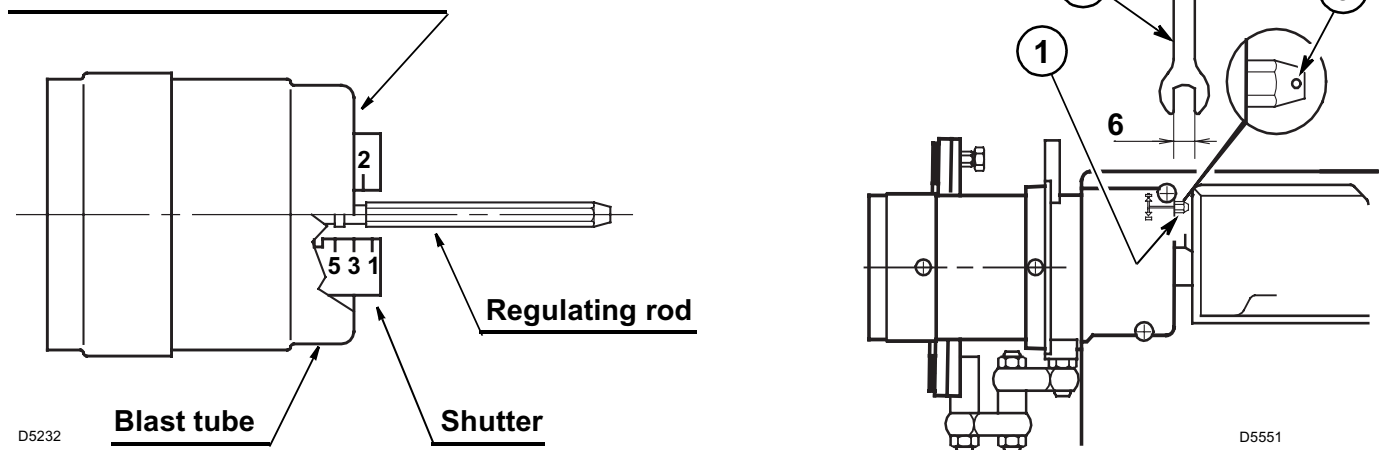

Combustion head settings indicated in the schedule are valid for most cases.

The setting of the fan output according to the installation should normally be done only through the air damper. Should one subsequently want to retouch also the setting of the combustion head, with the burner running, operate on the rod (1) with a 6 mm spanner (2) as follows:

TURN TO THE RIGHT: (SIGN +)

In order to increase the volume of air entering the combustion chamber and thus diminishing its pressure.

There is a reduction of CO₂ and the adhesion of the flame to the air diffuser disc improves. (Setting advisable for ignitions at low temperatures).

TURN TO THE LEFT: (SIGN -)

In order to reduce the volume of air entering the combustion chamber and thus increasing its pressure. The CO₂ improves and the adhesion of the flame to the diffuser tends to reduce. (This setting is not advisable for ignitions at low temperatures).

In any case do not bring the combustion head setting more than one point away from that indicated in the schedule. One set-point corresponds to 3 turns of the rod; a hole (3) at its end facilitates counting the number of turns.

4 AIR DAMPER ADJUSTMENT:

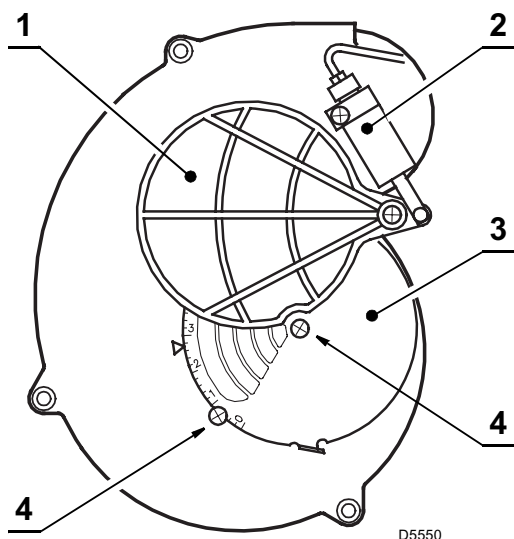

The mobile air damper (1) operated by the jack (2) assures the complete opening of the air intake.

The regulation of the air-rate is made by adjusting the fixed air damper (3), after loosening the screws (4). When the optimal regulation is reached, **screw tight the screws (4)** to assure a free movement of the mobile air damper (1).

The settings indicated in the schedule refer to the burner with its metal cover fitted and the combustion chamber with "zero" depression.

These regulations are purely indicative.

Each installation however, has its own unpredictable working conditions: actual nozzle output; positive or negative pressure in the combustion-chamber, the need of excess air, etc. All these conditions may require a different air-damper setting.

It is important to take account of the fact that the air output of the fan differs according to whether the burner has its metal cover fitted or not.

Therefore we recommended to proceed as follows:

- adjust the air damper as indicated in the schedule (4);
- mount the cover, simply by means of the upper screw;
- check smoke number;
- should it become necessary to modify the air output, remove the cover by loosening the screw, adjust the air damper, remount the cover and finally recheck the smoke number.

ELECTRODE SETTING

Attention:

Before removing or assembling the nozzle, loosen the screw (A) and move the electrodes ahead.

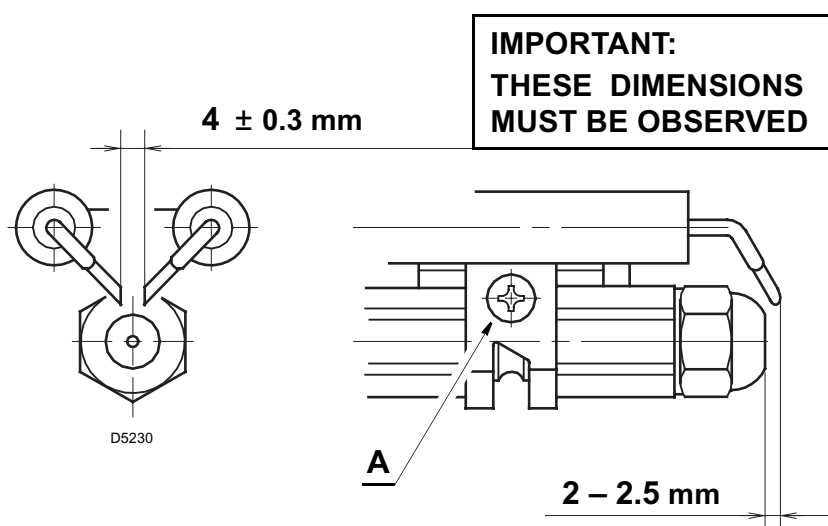

BURNER START-UP CYCLE



ONLY FOR LIGHT OIL ADJUSTMENTS, TO AVOID FLAME - DETACHMENT, AT BURNER - IGNITION

This inconvenience can occur, when the temperature of the light oil decreases below +8 °C.

1) CORRECT POSITIONING OF THE ELECTRODES

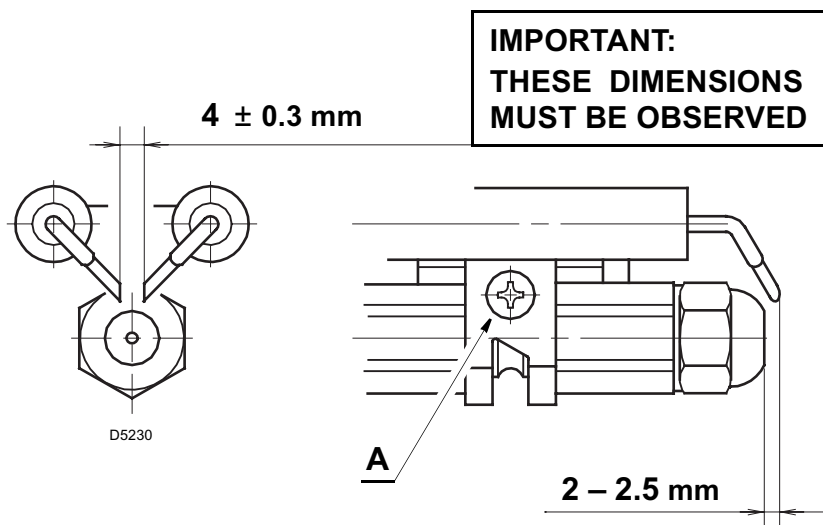

2) PUMP - SETTING

When the temperature of the light oil decreases below +8 °C, increase the pressure to 14 bar.

3) COMBUSTION-HEAD SETTING

Regulate the combustion-head one set-point further ahead than indicated in the instructions.

Example: *the instructions require to set the combustion-head on set-point 3.*

Instead, the setting is made on set-point 4.

4) FAN - AIR DAMPER ADJUSTMENT

Adjust the air damper of the fan, such as to obtain a smoke number not inferior to 1.
(i.e. a combustion with the lowest possible excess-air).

SAFETY WARNINGS

The dimension of the boiler's combustion chamber must respond to specific values, in order to guarantee a combustion with the lowest polluting emissions rate.

The Technical Service Personnel will be glad to give you all the information for a correct matching of this burner to the boiler.

This burner must only be used for the application it was designed for.

The manufacturer accepts no liability within or without the contract for any damage caused to people, animals and property due to installation, adjustment and maintenance errors or to improper use.

BURNER IDENTIFICATION

The Identification Plate on the product gives the serial number, model and main technical and performance data.

If the Identification Plate is tampered with, removed or missing, the product cannot be clearly identified thus making any installation or maintenance work potentially dangerous.

BASIC SAFETY RULES

- Children or inexpert persons must not use the appliance.
- Under no circumstances must the intake grids, dissipation grids and ventilation vents in the installation room be covered up with cloths, paper or any other material.
- Unauthorised persons must not attempt to repair the appliance.
- It is dangerous to pull or twist the electric leads.
- Cleaning operations must not be performed if the appliance is not disconnected from the main power supply.
- Do not clean the burner or its parts with inflammable substances (e.g. petrol, alcohol, etc.). The cover must be cleaned with soapy water.
- Do not place anything on the burner.
- Do not block or reduce the size of the ventilation vents in the installation room.
- Do not leave containers and inflammable products in the installation room.

