

## FCLI

Cassette-type fan coils with Brushless Inverter motor  
Continuous 0-100% air flow rate regulation  
False ceiling installation and cooling power from 1900 to 4980W



Aermec adheres to the EUROVENT Certification Programme. The products concerned appear in the EUROVENT Certified Products Guide.

Models:  
FCLI 32, FCL42, FCL62  
FCLI 34, FCL44, FCL64



GLLI10  
White: RAL 9010

### The future is Inverter

FCLI is the Aermec range of cassette-type fan coils with continuous 0-100% air flow rate variation and therefore continuous heating/cooling capacity variation.

Thanks to the Inverter technology, the FCLI continuously modifies the air flow rate, adapting it - moment by moment - to the real needs in the room.

This produces considerable advantages in terms of electric savings, comfort and noise reduction compared with a traditional on-off 3-speed fan coil.

- **ELECTRIC SAVINGS OF 50% COMPARED WITH A FAN COIL WITH TRADITIONAL 3-SPEED MOTOR**
- **VERY QUIET OPERATION**
- **TOTAL COMFORT: REDUCED TEMPERATURE AND HUMIDITY VARIATIONS IN THE AIR-CONDITIONED ROOMS**
- **STANDARD INTERNAL THREE-WAY VALVE, WITH FAST CONNECTION ACTUATOR AND POSITION VISUAL SIGNALLING**
- **VERSION WITH 2-WAY VALVE FOR VARIABLE WATER FLOW RATE SYSTEMS**
- **VERSION WITHOUT VALVES**
- **THERMAL EXCHANGE BATTERY WITH SHAPED PROFILE AND ENHANCED SURFACE**
- **FAN FOR LOW SOUND EMISSIONS**
- **VERSIONS FOR SYSTEMS WITH 2 AND 4 PIPES**

### Characteristics

- Fan unit with Brushless motor (Continuous 0-100% speed variation);
- 3 sizes for 2-pipe versions:  
FCL 32-42-62
- 3 sizes for 4-pipe versions:  
FCL 34-44-64
- Standard preparation with standard internal three-way valve, with fast connection actuator and visual signalling of the position
- FCL\_V2 preparation (available upon request), with internal two-way valve, suitable for variable water flow rate systems
- FCL\_VL preparation (available upon request), without internal valve
- Requires matching with the obligatory accessories, grill and control panel, necessary for the operation
- High design aesthetics
- Grille dimensions that can be perfectly incorporated into standard suspended ceiling panel sizes (600x600 mm).
- Fan for low sound emissions
- EUROVENT certification
- Fan unit with Brushless motor (Continuous 0-100% speed variation)
- The load-bearing structure, reinforced with a galvanised steel side band, contains insulation elements in expanded polystyrene obtained from injection moulding for purposes of noise reduction and air routing
- The condensation drip tray is in one piece, with V0 self-extinguishing level and joined by means of over-moulding technology to the insulation in expanded polystyrene with flame retardant additive
- Heat exchanger with shaped profile to increase the exchange surface, and easily accessible drain valves
- Possibility of direct release of external air regardless of indoor unit ventilation
- Possibility to control the climate of adjacent rooms as well
- Air filter easily removed and cleaned, self-supporting structure, characterised by a high efficiency and low pressure drops, with a fire resistance class V0 (UL 94).
- Electrostatically pre-charged air filter regenerated with fire resistance class 2 (UL 900), (FEL 10 accessory)
- Full compliance with the accident prevention standards
- Ease of installation and maintenance

## Brushless electric motor

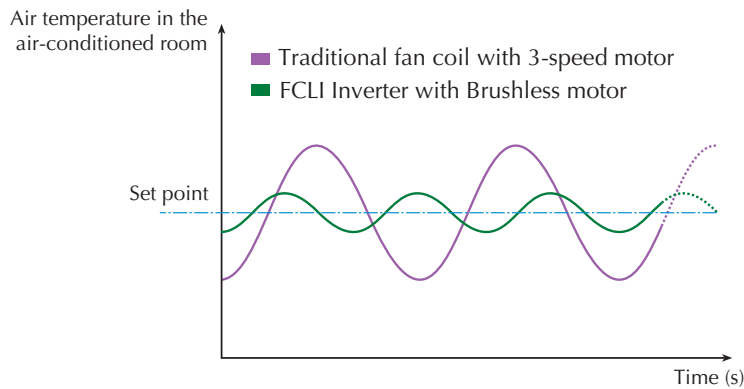

The "brushless" electric motor is the result of combining the most sophisticated technologies from the fields of mechanics and electronics. "Brushless" literally means "without brushes". The brushless electric motor has no sliding contacts between the rotor and the stator.

In brushless motors, the rotor consists of permanent magnets whose magnetic field interacts - without any mechanical contact - with the stator windings. With the special inverter device, it is possible to control the speed and torque of the rotor continuously, just by means of the stator currents.

Compared with the traditional alternate current motors, the brushless motor offers huge advantages:

- Reduced wear and tear
- the possibility to adjust the rotation speed accurately and continuously (0-100%)
- Higher energy yields
- Longer life and greater reliability

These characteristics have made the brushless motor irreplaceable in a wide variety of applications:

- robotics
- automotive
- precision drives
- CD/DVD players
- medical equipment
- etc.

Thanks to Aermec's FCXI range of inverter fan coils, brushless technology can now make inroads in the field of chilled water air conditioning, bringing notable energy savings along with the precise control of both air temperature and humidity in the air-conditioned rooms.

## Accessories

### Obligatory accessories, essential for unit operation:

- **GLL10** (600x600)  
Delivery grille with blades manually adjustable and air intake. Combined with wall-mounted control panel. White RAL 9010.
- **WMT20**: Control panel with electronic thermostat and LCD monitor. Wall mounting.

### Accessories:

- **FEL10**: electrostatically pre-charged air filter, regenerated with fire resistance class 2 (UL 900).
- **KFL**: Delivery flange, allowing the air to be directed to an adjacent room.
- **KFLD**: suction flange, allowing the air to be directed to an adjacent room.
- **VHL1**: motor-driven three-way valve for the heating battery in 4-pipe systems. Obligatory accessory in the 4-pipe systems.
- **VHL2**: motor-driven two-way valve for the heating battery in 4-pipe systems. Obligatory

accessory for 4-pipe systems with variable flow rates.

- **SWI**: Water temperature probe for WMT20 control panels. Cable length L = 2m.

### Compatibility of accessories

Mod. FCL	32	34	42	44	62	64
GLL10	✓	✓	✓	✓	✓	✓
WMT20	✓	✓	✓	✓	✓	✓
FEL10	✓	✓	✓	✓	✓	✓
KFL	✓	✓	✓	✓	✓	✓
KFLD	✓	✓	✓	✓	✓	✓
VHL1		✓		✓		✓
VHL2		✓		✓		✓
SWI	✓	✓	✓	✓	✓	✓

## Technical data

Mod. FCL	2-pipe versions		32	42	62
Heating capacity 50°C (E)	speed (max)	- W	2380	4950	6250
Pressure drops (VL) 50°C (E)	speed (max)	kPa	9	23	32
Total cooling capacity (E)	speed (max)	W	1900	3950	4980
Sensible cooling capacity (E)	speed (max)	W	1520	3160	3815
Water flow rate	speed (max.)	l/h	327	679	857
Pressure drops (VL) (E)	speed (max)	kPa	10	25	36
Air flow rate (E)	speed (max.)	m <sup>3</sup> /h	600	700	880
	speed (min)	m <sup>3</sup> /h	150	150	150
Fans		n.	1	1	1
Sound power (E)	speed (max)	dB(A)	46	53	61
	speed (min)	dB(A)	31	32	33
♪ Sound pressure	speed (max)	dB(A)	37	42	52
	speed (min)	dB(A)	22	23	24
Heat exchanger water content		l	1.2	1.5	3
Water connections		ø Gas	3/4"	3/4"	3/4"
Kvs (standard version 3R valve)			2.5	2.5	2.5
Input power (E)	(max)	W	33	55	61
Input current	(max)	A	0.28	0.43	0.47

Mod. FCL	4-pipe versions		34	44	64
Heating capacity 70°C (E)	speed (max)	W	2600	3070	3800
Water flow rate 70°C		l/h	224	264	327
Pressure drops (VL) 70°C (E)		kPa	11	14	21
Total cooling capacity (E)	speed (max)	W	1900	3650	4610
Sensible cooling capacity (E)	speed (max)	W	1520	2920	3530
Water flow rate	speed (max.)	l/h	327	628	793
Pressure drops (VL) (E)	speed (max)	kPa	10	22	31
Air flow rate (E)	speed (max.)	m <sup>3</sup> /h	600	700	880
	speed (min)	m <sup>3</sup> /h	150	150	150
Fans		n.	1	1	1
Sound power (E)	speed (max)	dB(A)	46	53	61
	speed (min)	dB(A)	31	32	33
♪ Sound pressure	speed (max)	dB(A)	37	42	52
	speed (min)	dB(A)	22	23	24
Heat exchanger water content		l	1.2	1.5	3
Heat exchanger water content (hot circuit)		l	0.3	0.5	1.5
Water connections		ø Gas	3/4"	3/4"	3/4"
Water connections (hot circuit)		ø Gas	1/2"	1/2"	1/2"
Kvs (standard version 3R valve)			2.5	2.5	2.5
Kvs (hot circuit valve)			2.5	2.5	2.5
Input power (E)	(max)	W	33	55	61
Input current	(max)	A	0.28	0.43	0.47

Power supply = 230V~ 50Hz

(E) = EUROVENT certificate performances

The performances are the same for all the configurations:  
FCL (standard), FCL V2 and FCL VL.

Performance values refer to the following conditions:

♪ Sound pressure measured in a semi-reverberating chamber of  
100 cu.m and with a reverberation time of Tr = 0.5 sec.

■ Cooling:

- room air temperature 27°C B.S., 19°C B.U;
- inlet water temperature 7°C; maximum speed;  
Δt water 5°C.

■ Heating:

- room air temperature 20°C ;
- inlet water temperature: 70°C; Δt water 10°C;
- inlet water temperature: 50°C; maximum speed;
- water flow rate as in cool mode;

## Dimensions (mm)

FCLI 32 - 34 - 42 - 44 - 62 - 64  
 FCLI 32 V2 - 34 V2 - 42 V2 - 44 V2 - 62 V2 - 64 V2  
 FCLI 32 VL - 34 VL - 42 VL - 44 VL - 62 VL - 64 VL

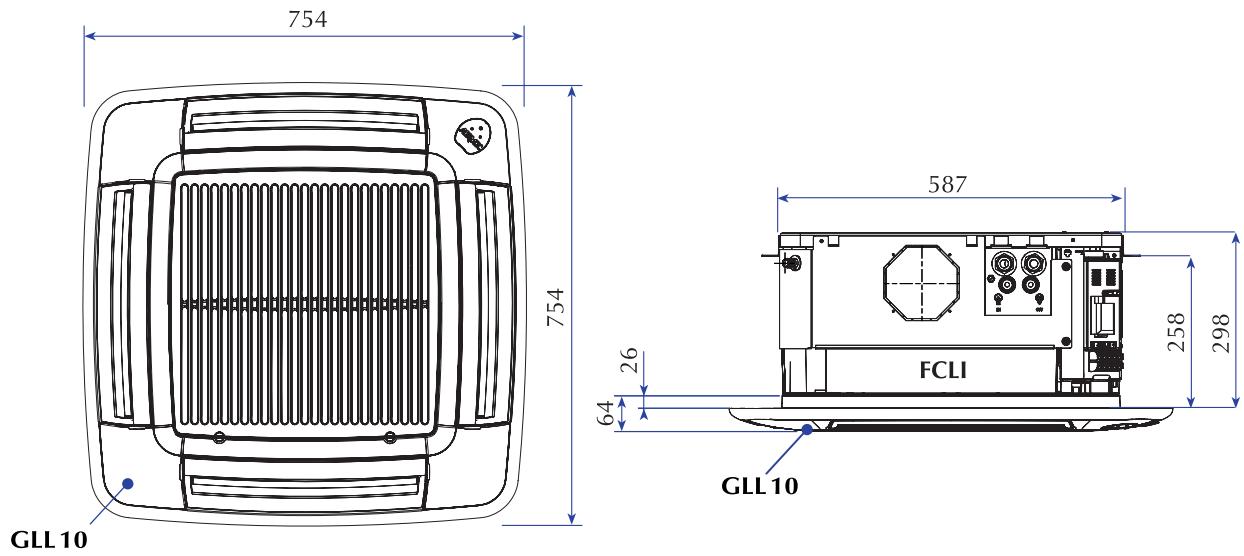

<b>Mod. FCLI</b>		<b>32</b>	<b>34</b>	<b>42</b>	<b>44</b>	<b>62</b>	<b>64</b>
Weight	kg	20.5	21	20.5	21	22	22.5
<b>Mod. FCLI</b>		<b>32 V2</b>	<b>34 V2</b>	<b>42 V2</b>	<b>44 V2</b>	<b>62 V2</b>	<b>64 V2</b>
Weight	kg	20.5	21	20.5	21	21	22.5
<b>Mod. FCLI</b>		<b>32 VL</b>	<b>34 VL</b>	<b>42 VL</b>	<b>44 VL</b>	<b>62 VL</b>	<b>64 VL</b>
Weight	kg	20	20.5	20	20.5	21.5	22