

CE

RIELLO
BURNERS

▶ **RL/M BLU SERIES** ▶ **RL 55/M BLU** 188/360 ÷ 720 kW
 ▶ **RL 85/M BLU** 223/594 ÷ 1023 kW

LOW NO_x MODULATING LIGHT OIL BURNERS



The RL/M BLU burners series covers a firing range from 188 to 1023 kW, and it has been designed for use in hot or superheated water boilers, hot air or steam generators and diathermic oil boilers. Operation can be "two stage progressive" or, alternatively, "modulating" with the installation of a PID logic regulator and respective probes. RL/M BLU burners series guarantees high efficiency levels in all applications, thus reducing fuel consumption and running costs. Sound emissions optimisation is guaranteed by the use of fans with reverse curve blades and sound deadening material incorporated in the air suction circuit. The exclusive design ensures reduced dimensions, simple use and maintenance. A wide range of accessories guarantees elevated working flexibility.

TECHNICAL DATA

Model		▼ RL 55/M BLU	▼ RL 85/M BLU
Burner operation mode		Modulating (with regulator and probes accessories)	
Modulation ratio at max. output		2 ÷ 1	
Servomotor	type	SQN31	
	run time	s	
Heat output	kW	188/360÷720	223/594÷1023
	Mcal/h	162/310÷620	192/512÷882
	kg/h	16/30÷60	18,8/50÷86,2
Working temperature		°C min./max.	
Net calorific value	kWh/kg	11,8	
	kcal/kg	10200	
Viscosity		mm ² /s (cSt)	
Pump	type	J 6	
	delivery	kg/h	
Atomised pressure		bar	
Fuel temperature		Max. °C	
Fuel pre-heater			
Fan		Centrifugal with reverse curve blades	
Air temperature		Max. °C	
Electrical supply		Ph/Hz/V	
Auxiliary electrical supply		Ph/Hz/V	
Control box		type	
Total electrical power		kW	
Auxiliary electrical power		kW	
Heaters electrical power		kW	
Protection level		IP	
Pump motor electrical power		kW	
Rated pump motor current		A	
Pump motor start up current		A	
Pump motor protection level		IP	
Fan motor electrical power		kW	
Rated fan motor current		A	
Fan motor start up current		A	
Fan motor protection level		IP	
Ignition transformer		type	
		V1 - V2	
		I1 - I2	
Operation		Intermittent (at least one stop every 24 h) - Continuous (at least one stop every 72 h)	
Sound pressure		dB(A)	
Sound power		W	
CO emission		mg/kWh	
Grade of smoke indicator		N° Bacharach	
CxHy emission		mg/kWh	
NOx emission		mg/kWh	
Directive		73/23 - 89/336 - 98/37 EEC	
Conforming to		EN 267	
Certification		in progress	

Reference conditions:

Temperature: 20°C
 Pressure: 1000 mbar
 Altitude: 100 m a.s.l.
 Noise measured at a distance of 1 meter.

Since the Company is constantly engaged in the production improvement, the aesthetic and dimensional features, the technical data, the equipment and the accessories can be changed.

This document contains confidential and proprietary information of RIELLO S.p.A. Unless authorised, this information shall not be divulged, nor duplicated in whole or in part.



FIRING RATES

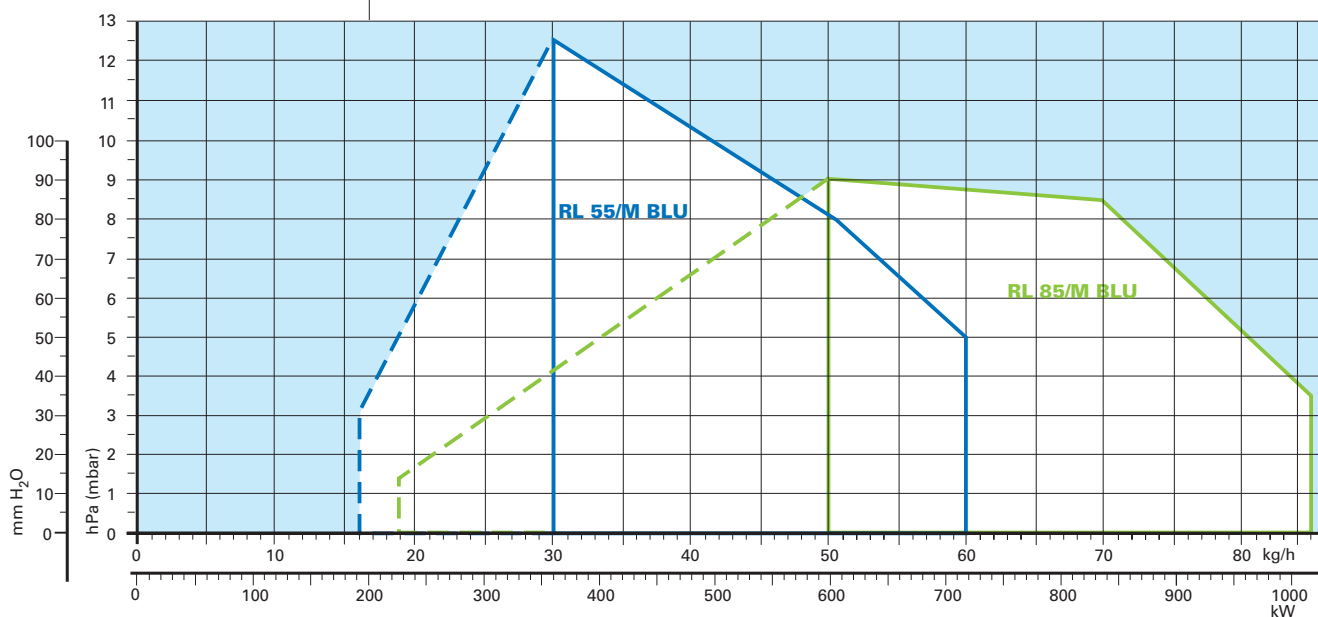

Useful working field for choosing the burner

Modulation range

Test conditions conforming to EN 267:

Temperature: 20°C
Pressure: 1000 mbar
Altitude: 100 m a.s.l.

note

The RL 55-85/M BLU burners are designed exclusively for combustion chambers with flue gas outlet from the bottom, for example three flue gas passes (not reverse flame boilers) accessible through the door. Maximum thickness of the frontal boiler wall: 250 mm. Exhaust gases ducts must be always and exclusively directed upwards; change in directions must be realized only by bent elements; the angle between the axis of the stroke coming out of the combustion chamber and the axis of the chimney must be smaller than 45°.



FUEL SUPPLY

HYDRAULIC CIRCUITS

Various hydraulic circuits are available, depending on fuel output asset according to local norms of steam generators.

The burners are fitted with two valves for oil output from the pump: a pressure regulator on the return circuit from the nozzle allows varying the quantity of burnt fuel. A safety valve on the return circuit impedes oil leakage from the nozzle when the burner is in stand by and pre-purge phases.

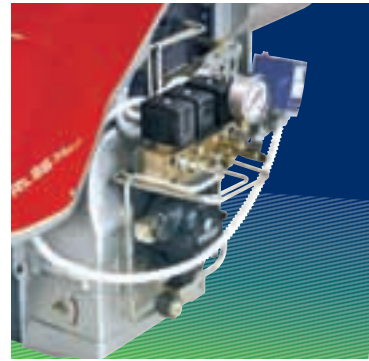

Example of the hydraulic circuit on RL 85/M BLU burners

EN 267

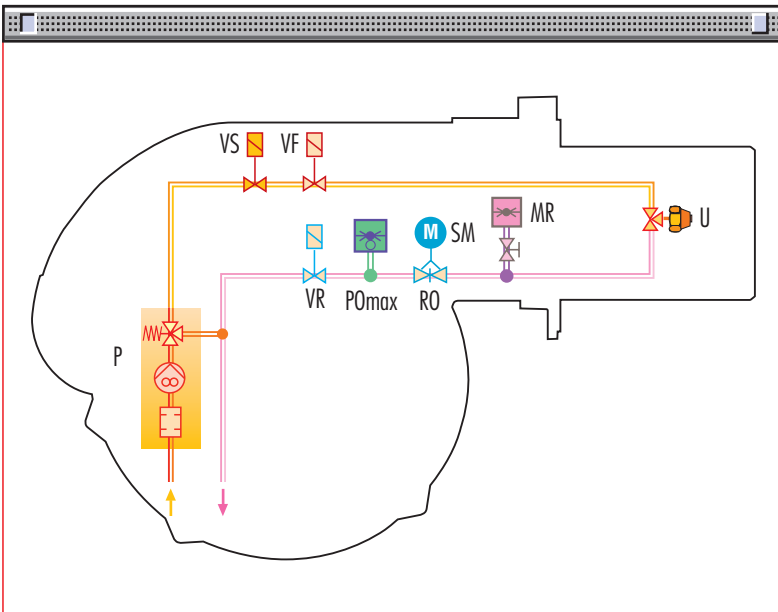

P	Pump with filter and pressure regulator on the output circuit
VS	Safety valve on the output circuit
VF	Working valve on the output circuit
U	Nozzle
MR	Pressure gauge on the return circuit
SM	Servomotor
RO	Pressure regulator on the return circuit
PO max	Max. Oil pressure switch on the return circuit
VR	1st safety valve on the return circuit



SELECTING THE FUEL SUPPLY LINES

The fuel feed must be completed with the safety devices required by the local norms.

The table shows the choice of piping diameter for the various burners, depending on the difference in height between the burner and the tank and their distance.

MAXIMUM EQUIVALENT LENGTH FOR THE PIPING L[m]			
Model	▼ RL 55-85/M BLU		
Diameter piping	Ø12mm	Ø14mm	Ø16mm
+H, -H (m)	L _{max} (m)	L _{max} (m)	L _{max} (m)
+4,0	71	138	150
+3,0	62	122	150
+2,0	53	106	150
+1,0	44	90	150
+0,5	40	82	150
0	36	74	137
-0,5	32	66	123
-1,0	28	58	109
-2,0	19	42	81
-3,0	10	26	53
-4,0	-	10	25

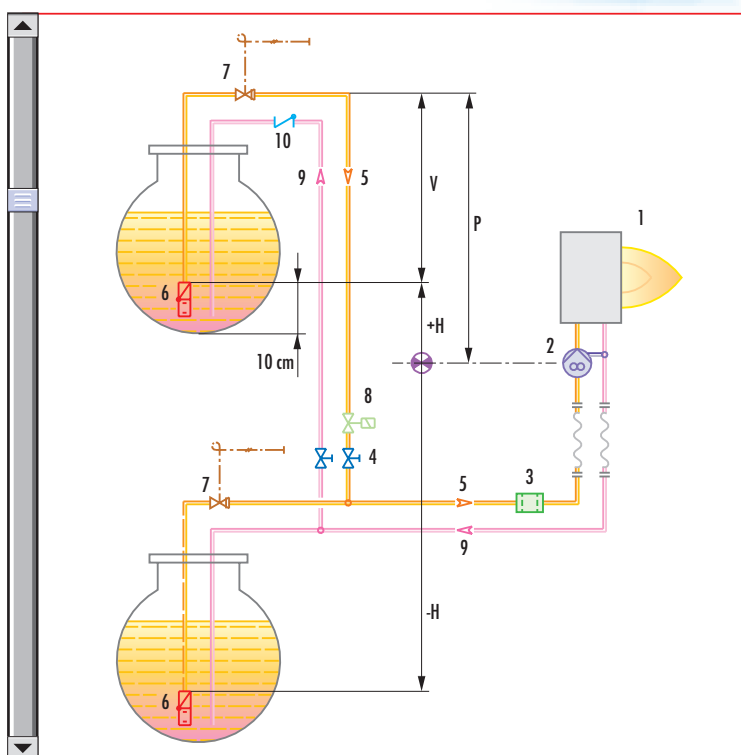

H	Difference in height pump-foot valve
Ø	Internal pipe diameter
P	Height 10 m
V	Height 4 m
1	Burner
2	Burner pump
3	Filter
4	Manual shut off valve
5	Suction pipework
6	Bottom valve
7	Remote controlled rapid manual shut off valve (compulsory in Italy)
8	Type approved shut off solenoid valve (compulsory in Italy)
9	Return pipework
10	Check valve

note With ring distribution oil systems, the feasible drawings and dimensioning are the responsibility of specialised engineering studios, who must check compatibility with the requirements and features of each single installation.



VENTILATION

The ventilation circuit produces low noise levels with high performance pressure and air output, in spite of the compact dimensions.

The use of reverse curve blades and sound proofing material keeps noise level very low.

A variable profile cam connects fuel and air setting, ensuring high fuel efficiency in all firing ranges.

Example of the servomotor for air/oil setting

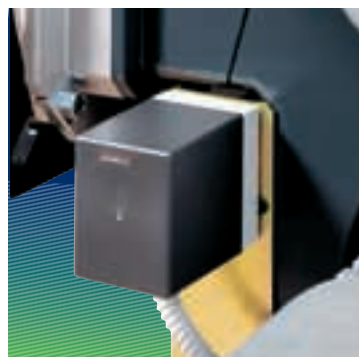

COMBUSTION HEAD

The combustion head has been designed to create partial smoke recirculation; this way, thanks to lower temperatures reached, NOx emissions are reduced, taking the value below the level allowed by the strictest norms.

Depending on the type of generator, check that the penetration of the head into the combustion chamber is correct.

The internal positioning of the combustion head can easily be adjusted to the maximum defined output by adjusting a screw fixed to the flange.

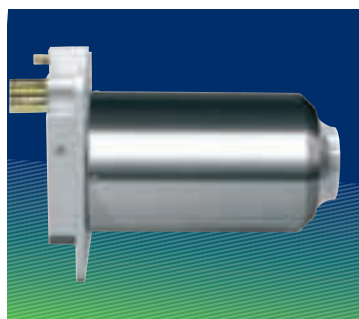

Example of a RL/M BLU burner combustion head

Flame dimensions

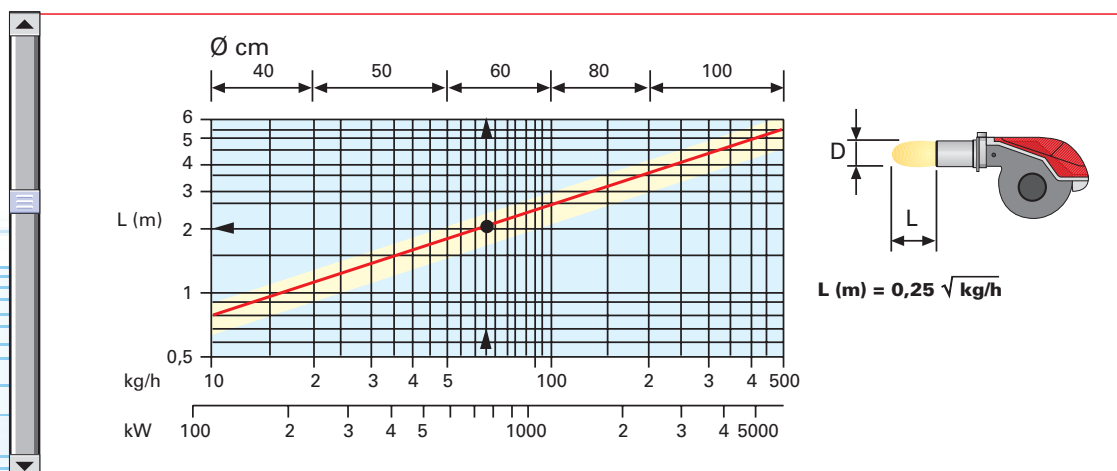

ADJUSTMENT



BURNER OPERATION MODE

The RL/M BLU series of burners can have "two-stage progressive" or "modulating" operation.

On "two-stage progressive" operation, the burner gradually adapts the output to the requested level, by varying between two pre-set levels (see picture A).

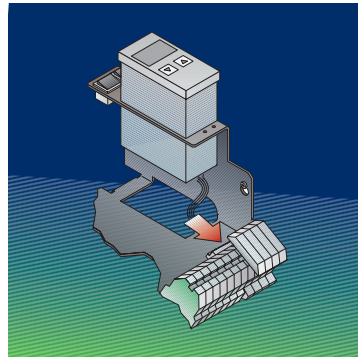

Example of a regulator

"Two-stage progressive" operation

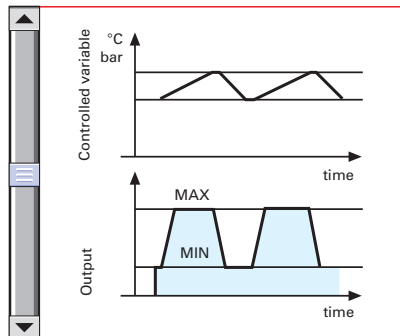

Picture A

On "modulating" operation, normally required in steam generators, in superheater boilers or diathermic oil burners, a specific regulator and probes are required. These are supplied as accessories that must be ordered separately. The burner can work for long periods at intermediate output levels (see figure B).

"Modulating" operation

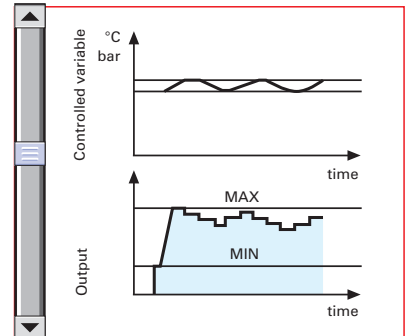

Picture B

START UP CYCLE

RL 55-85/M BLU

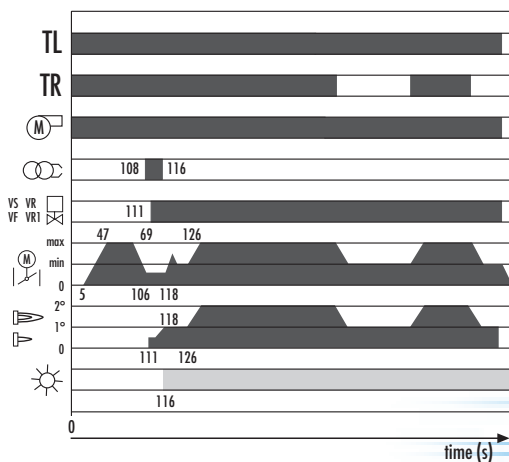

- 0" The burner begins the firing cycle: the motor starts turning.
- 5"-47" The servomotor opens the air damper.
- 47"-69" Pre-purge with the air damper open.
- 69"-106" The servomotor takes the air damper to the firing position.
- 108" Pre-ignition.
- 111" Firing: all the oil solenoid valves are supplied.
- 118" Servomotor control for minimum modulation position.
- 126" Output can be increased.





WIRING DIAGRAMS

Electrical connections must be made by qualified and skilled personnel, according to the local norms.



Example of the terminal board for electrical connections for the RL 55-85/M BLU models

“TWO-STAGE PROGRESSIVE” OPERATION

RL 55-85/M BLU

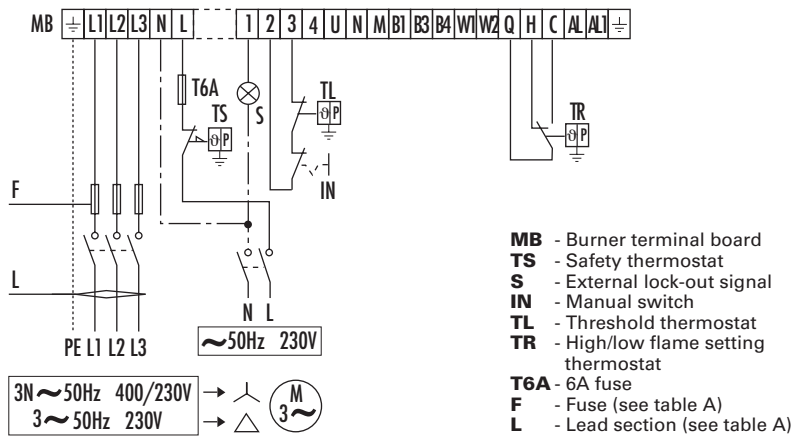

“MODULATING” OPERATION - temperature probe

RL 55-85/M BLU

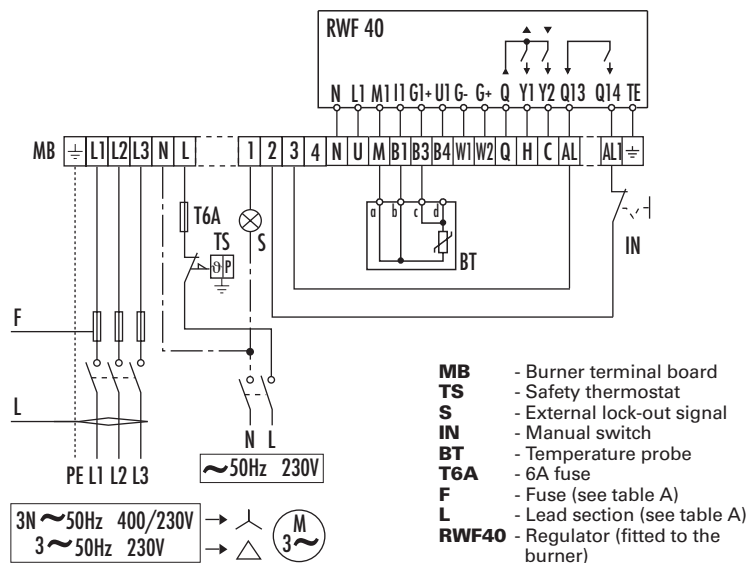



► **“MODULATING” OPERATION - pressure probe**

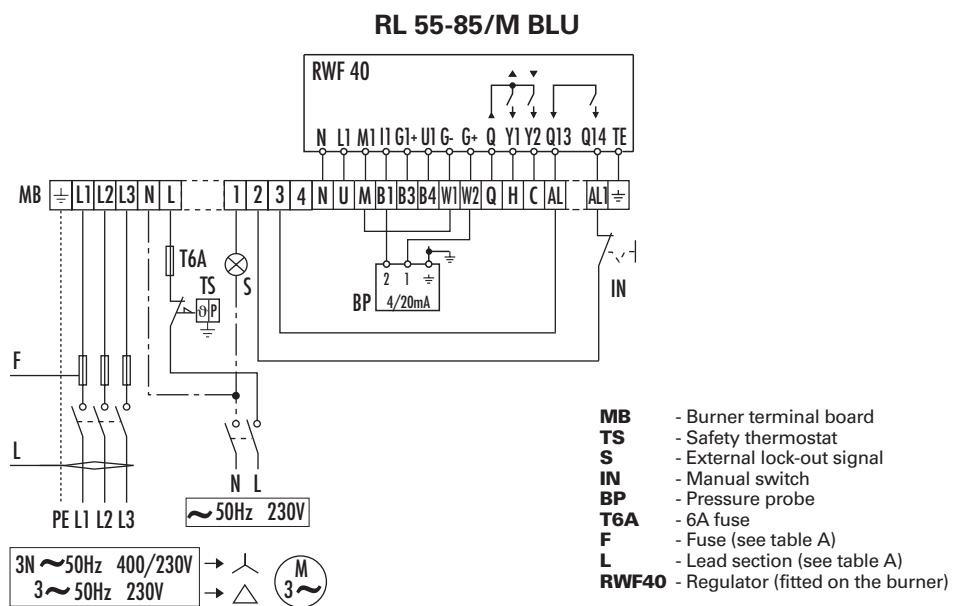

The following table shows the supply lead sections and the type of fuse to be used.

Model	▼ RL 55/M BLU		▼ RL 85/M BLU	
	230V	400V	230V	400V
F A	T10	T6	T16	T10
L mm ²	1,5	1,5	1,5	1,5

Table A





EMISSIONS

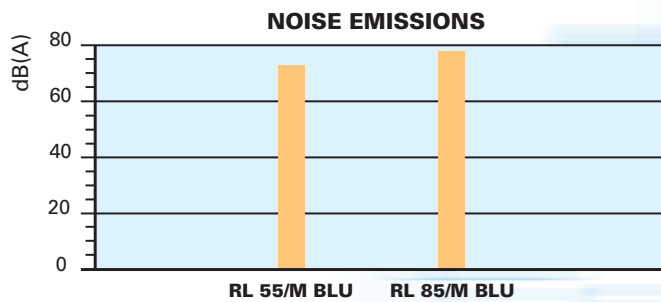
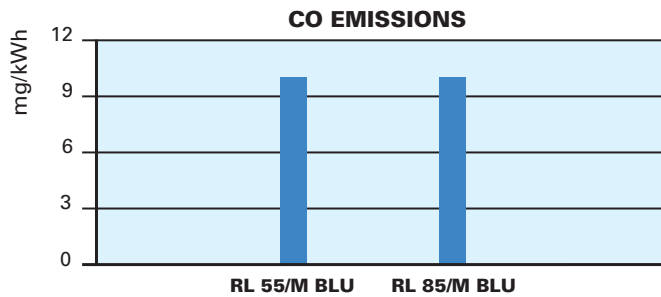
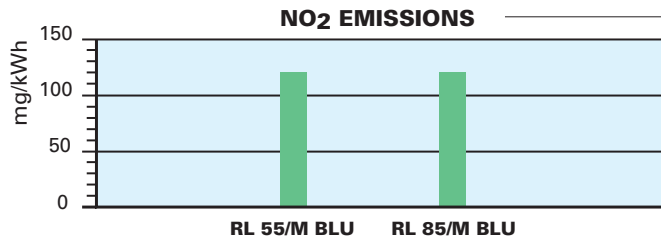

The emission data has been measured in the various models at maximum output, according to EN 267 standard.

Combustion head operating diagram

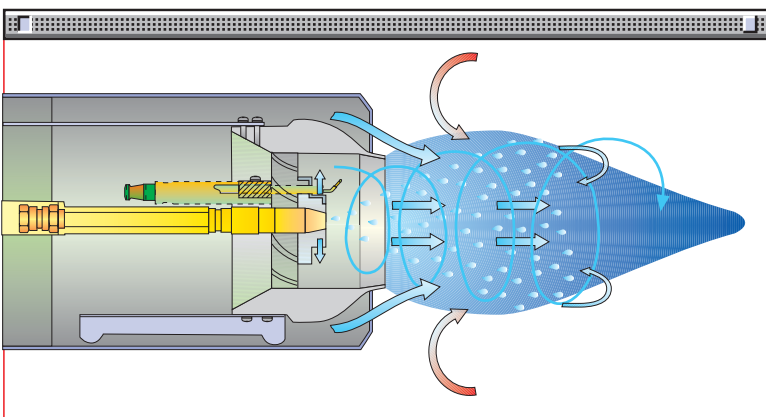

The combustion head on the RL 55-85/M BLU burners is conical and its operating principle is based on recirculating the combustion exhaust gas; even air distribution to the head guarantees an optimum mix to the elements. The special design of the central diffuser also allows excellent ignition and air control.

The first quantity of air is aimed towards the centre of the head, where combustion develops to avoid strong flame oxidation. A second part is directed towards the flame stability disc where, due

to the conic shape of the mobile shutter, it gains speed and activates smoke recirculation. All these devices aid the reduction of polluting emissions, allowing to obtain values lower than the levels allowed by the strictest regulations norms.

OVERALL DIMENSIONS (mm)



BURNER

RL 55-85/M BLU

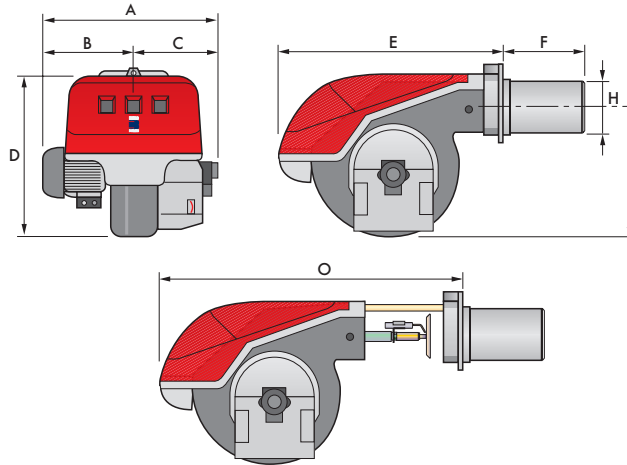

Model	A	B	C	D	E	F	H	I	O
▶ RL 55/M BLU	663	296	367	555	680	365	189	430	951
▶ RL 85/M BLU	705	338	367	555	680	365	189	430	951

BURNER - BOILER MOUNTING FLANGE

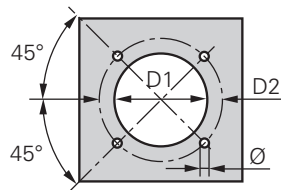

Model	D1	D2	Ø
▶ RL 55/M BLU	195	275-325	M12
▶ RL 85/M BLU	195	275-325	M12

PACKAGING

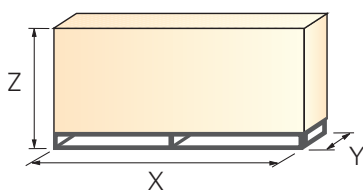

Model	X	Y	Z	kg
▶ RL 55/M BLU	1270	745	885	65
▶ RL 85/M BLU	1270	745	885	70



INSTALLATION DESCRIPTION

Installation, start up and maintenance must be carried out by qualified and skilled personnel. All operations must be performed in accordance with the technical handbook supplied with the burner.

BURNER SETTING

- ▶ All the burners have slide bars, for easier installation and maintenance.
- ▶ After drilling the boilerplate, using the supplied gasket as a template, dismantle the blast tube from the burner and fix it to the boiler.
- ▶ Adjust the combustion head.
- ▶ Refit the burner casing to the slide bars.
- ▶ Install the nozzle, choosing this on the basis of the maximum boiler output and following the diagrams included in the burner instruction handbook.
- ▶ Check the position of the electrodes.
- ▶ Close the burner, sliding it up to the flange, keeping it slightly raised to avoid the flame stability disk rubbing against the blast tube.



HYDRAULIC / ELECTRICAL CONNECTIONS AND START UP

- ▶ The burners are supplied for connection to two pipes fuel supply system.
- ▶ Connect the ends of the flexible pipes to the suction and return pipework using the supplied nipples.
- ▶ Make the electrical connections to the burner following the wiring diagrams included in the instruction handbook.
- ▶ Prime the pump by turning the motor (after checking rotation direction if it is a three phase motor).
- ▶ On start up, check:
 - Pressure pump and valve unit regulator (to max. and min.)
 - Combustion quality, in terms of unburned substances and excess air.



BURNER ACCESSORIES



Nozzles

The return nozzles must be ordered separately. The following table shows the features and codes on the basis of the maximum required fuel output.

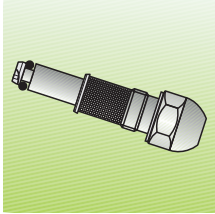

Nozzles type A3 60°		
Burner	Rated delivery (kg/h) (*)	Code
RL 55-85/M BLU	30	3009867
	40	3009868
	50	3009869
	60	3009870
	90	3009871

(*) Nozzle rated delivery is referred to atomised pressure

Spacer kit

If burner head penetration into the combustion chamber needs reducing, varying thickness spacers are available, as given in the following table:

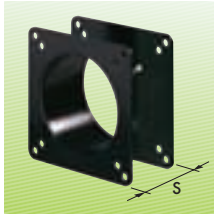

Spacer kit		
Burner	Spacer thickness S (mm)	Kit code
RL 55-85/M BLU	135	3010129

Sound proofing box

If noise emission needs reducing even further, sound-proofing boxes are available, as given in the following table:



Sound proofing box			
Burner	Type	Average noise reduction [dB(A)]	Code
RL 55-85/M BLU	C3	14	3000778

Degasing unit

To solve problem of air in the oil sucked, two versions of degasing unit are available.



Degasing unit			
Burner	Filter	Filtering degree (µm)	Degasing unit code
RL 55-85/M BLU	With filter	50 - 75	3010055
RL 55-85/M BLU	Without filter	-	3010054

note For burner deliveries higher than 80 kg/h, install two parallel degasing units.

Accessories for modulating operation

To obtain modulating operation, the RL/M BLU series of burners requires a regulator with three point outlet controls. The following table lists the accessories for modulating operation with their application range.



Regulator		
Burner	Type	Code
RL 55-85/M BLU	RWF 40	3010212

The relative temperature or pressure probes fitted to the regulator must be chosen on the basis of the application.



Probe		
Type	Range (°C) (bar)	Code
Temperature PT 100	-100 ÷ 500°C	3010110
Pressure 4 ÷ 20 mA	0 ÷ 2,5 bar	3010213
Pressure 4 ÷ 20 mA	0 ÷ 16 bar	3010214

Depending on the servomotor fitted to the burner, a three-pole potentiometer (1000 Ω) can be installed to check the position of the servomotor. The KITS available for the various burners are listed below.

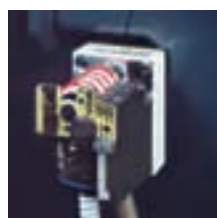

Potentiometer	
Burner	Potentiometer kit code
RL 55-85/M BLU	3010021

SPECIFICATION

A specific index guides your choice of burner from the various models available in the RL/M series. Below is a clear and detailed specification description of the product.



DESIGNATION OF SERIES

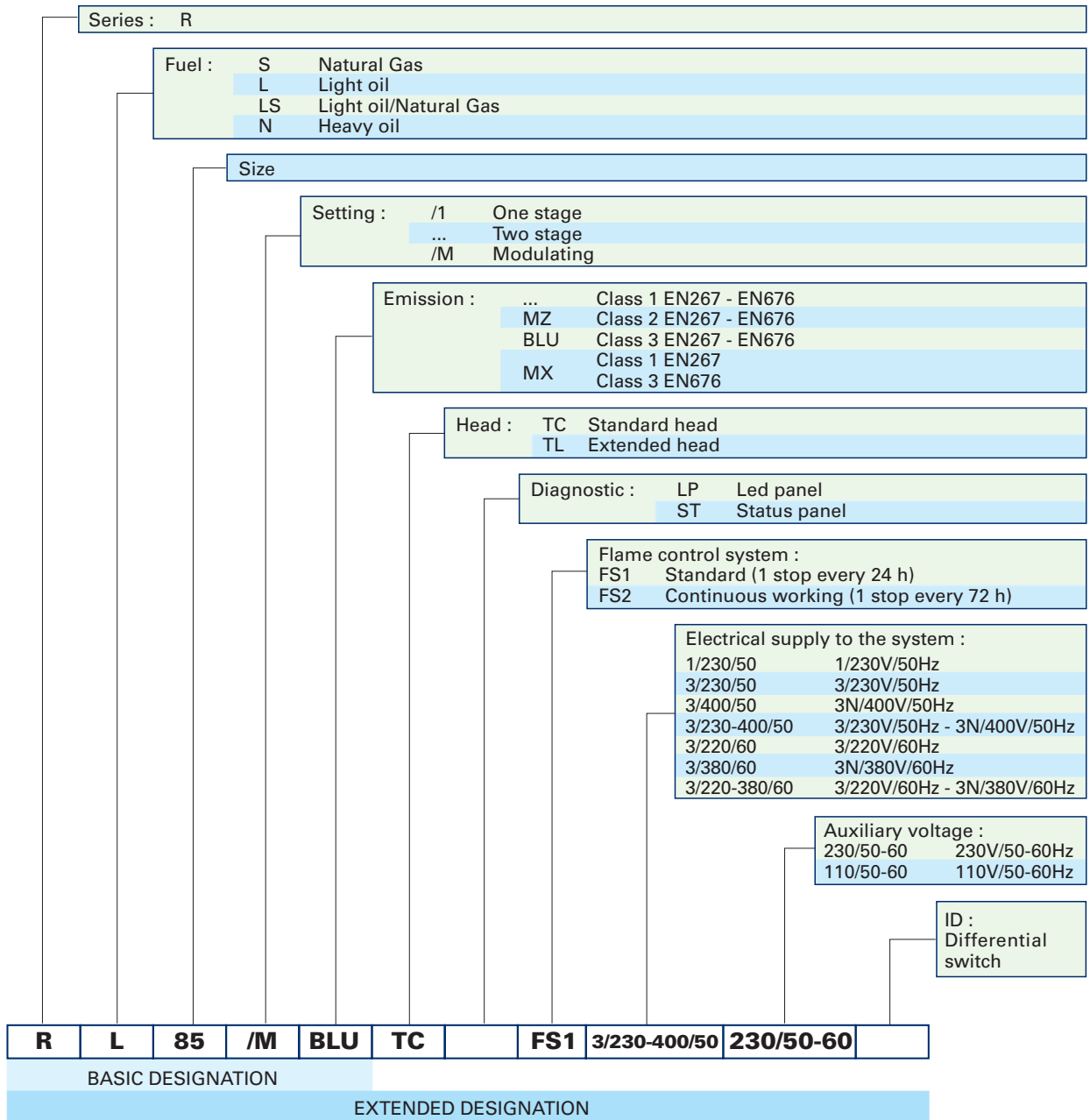

AVAILABLE BURNER MODELS

RL 55/M BLU TC FS1 3/230-400/50 230/50-60
 RL 85/M BLU TC FS1 3/230-400/50 230/50-60

Other versions with FS2 (continuous working) are available on request.



▶ PRODUCT SPECIFICATION

Burner:

Monoblock forced draught oil burner with two stage progressive or modulating setting, with a specific kit, fully automatic, made up of:

- air suction circuit lined with sound-proofing material
- fan with reverse curve blades high performance with low sound emissions
- air damper for air setting and automatic oil output regulator controlled by a servomotor with variable cam
- starting motor at 2800 rpm, three-phase 400V with neutral, 50Hz
- combustion head, that can be set on the basis of required output, fitted with:
 - stainless steel end cone, resistant to corrosion and high temperatures
 - ignition electrodes
 - flame stability disk
- gears pump for high pressure fuel supply, fitted with:
 - filter
 - pressure regulator
 - connections for installing a pressure gauge and vacuumeter
 - internal by-pass for single pipe installation
- valve unit with a double oil safety valve on the output circuit and safety valve on the return circuit; double safety valve on the return circuit
- safety oil pressure switch for stop the burner in case of problems in the return circuit
- photocell for flame detection
- flame control panel, fitted with control function for the correct positioning of the servomotor and possibility of post-ventilation by just changing the electric wiring
- burner on/off switch
- flame inspection window
- manual or automatic output increase/decrease switch
- slide bars for easier installation and maintenance
- protection filter against radio interference
- IP 44 electric protection level.

Conforming to:

- 89/336/EEC directive (electromagnetic compatibility)
- 73/23/EEC directive (low voltage)
- 92/42/EEC directive (performance)
- 98/37/EEC directive (machinery)
- EN 267 (liquid fuel burners).

Standard equipment:

- 2 flexible pipes for connection to the oil supply network
- 2 gaskets for the flexible pipes
- 2 nipples for connection to the pump
- 4 screws for fixing the burner flange to the boiler
- 1 thermal screen
- wiring loom fittings for electrical connections
- instruction handbook for installation, use and maintenance
- spare parts catalogue.

Available accessories to be ordered separately:

- return nozzles
- spacer kit
- sound-proofing box
- degasing unit
- RWF 40 output regulator
- temperature probe -100 – 500°C
- pressure probe 0 – 2.4 bar
- pressure probe 0 – 16 bar
- potentiometer kit for the servomotor.









RIELLO S.p.A. - Via Ing. Pilade Riello, 5 - 37048 San Pietro di Legnago (VR) Italy

Tel. ++39.0442630111 - Fax ++39.044221980

Internet: <http://www.rielloburners.com> - E-mail: info@rielloburners.com

Since the Company is constantly engaged in the production improvement, the aesthetic and dimensional features, the technical data, the equipment and the accessories can be changed.
This document contains confidential and proprietary information of RIELLO S.p.A.
Unless authorised, this information shall not be divulged, nor duplicated in whole or in part.

